

MINIMILL

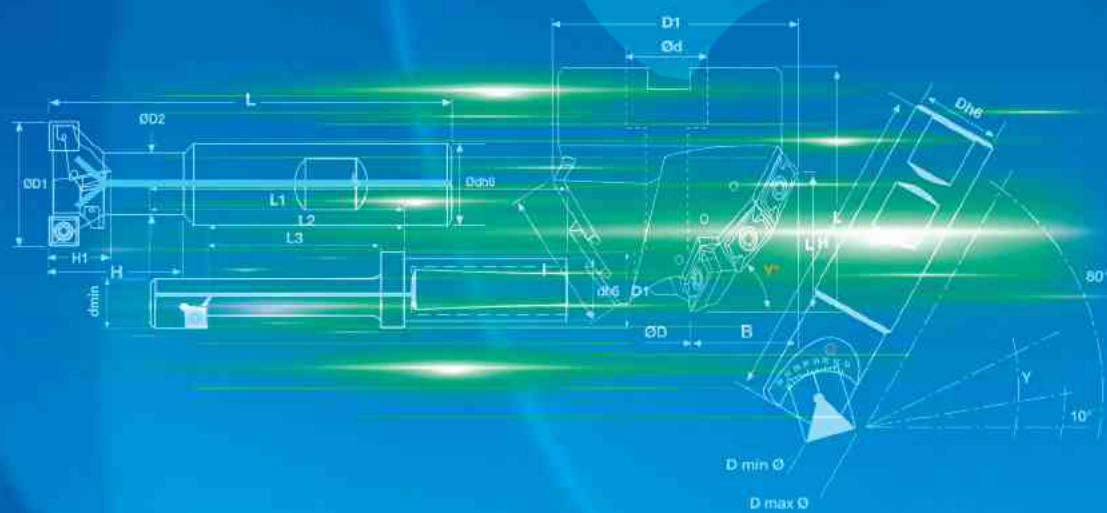

FRESE PER CAVE A T _ FRÄSER FÜR T-NUTEN _ T SLOT MILLING CUTTER

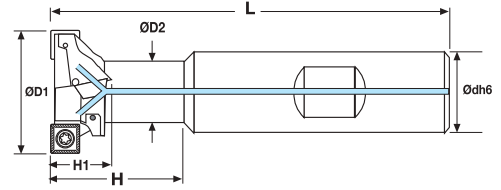

250 W

	ØD1	ØD2	L	H	H1	Ødh6	K	Z				KG	STOCK	€
250.021 WW	21	11	76	26	9	16	1	2	SPGT SPMT	VT25	BT08	0,100	●	306,50
250.025 WW	25	13	82	31	11	16	2	4	060304			0,100	●	363,00
250.032 WW	32	17	88	38	14	20	2	4	SPGT SPMT	VT35S	BT15	0,200	●	392,50
250.040 WW	40	21	108	50	17	25	2	4	09T308			0,400	●	422,50
250.050 WW	50	27	120	56	22	32	2	4	SPGT SPMT	VT50	BT20	0,670	●	480,50
									120408					

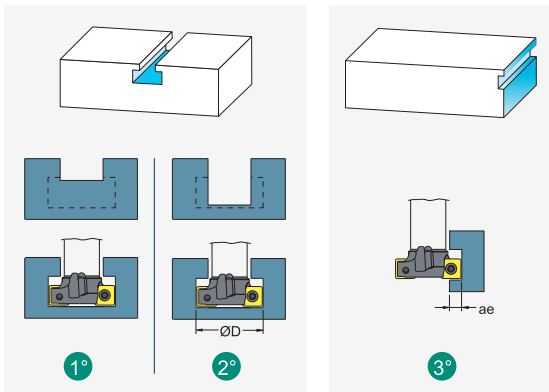

	1°	2°	3°	3°	2°	1°
ae/D	1	0,5	0,2	0,1	0,05	0,02
Kae	1	1	1,5	2,1	3	4,8

ae/D	0,5-1	0,2	0,1	0,05
50-100%	20%	10%	5%	2%

Vc

Vc (min)	-----	Vc(max)
R	-----	M
	-----	F

NOTE
 Per cave a "T" secondo norme DIN 650-UNI 4788-ISO 299
 Für "T" Nuten nach DIN 650-uni 4788-ISO 299 Normen
 For "T" slot cutters according to DIN 650-UNI4788-ISO 299 norms

Ve m/min VELOCITÀ DI TAGLIO - CUTTING SPEED
n giri/min (min-1) NUMERO DI GIRI - NUMBER OF REVOLUTIONS
fz mm AVANZAMENTO AL DENTE - TOOTH FEED
fn mm AVANZAMENTO AL GIRO - FEED I REVOLUTION
Vf mm/min VELOCITÀ DI AVANZAMENTO - FEED SPEED
Kae FATTORE DI CORREZIONE - CORRECTION FACTOR
F FINITURA, LAV. LEGGERA - FINISHING, LIGHT MACHINING
M LAV. MEDIA, GENERICA - MEDIUM MACHINING, GENERIC
R SGROSSATURA, LAV. PESANTE - ROUGHING, HEAVY MACHINING
Z Numero di eliche / Schraubenzahl / Number of flutes
K Fattore d'avanzamento / Vorschubfaktor / Factor of feed

FRESE FORANTI _ BOHRNUTFRÄSER _ DRILLING ENDMILL

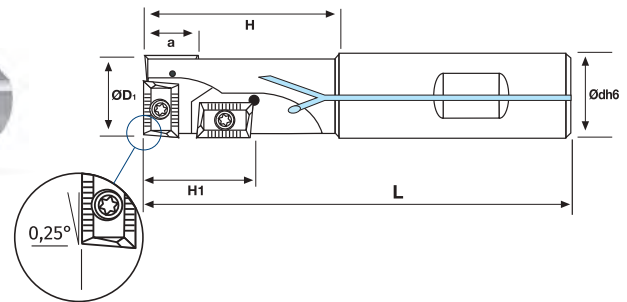
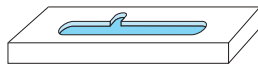

720 W

	ØD1	Ødh6	L	H	H1	a	Z				KG	STOCK	€	
720W W D20	20	20	90	35	17	9	3	APKT 1003...	VT25	BT08	0,200	●	222,00	
720W W D25	25	25	110	50	19	9	3				0,360	●	265,00	
720W W D32	32	32	130	50	30	15	3	APKT 1604...	VT40	BT15	0,720	●	283,00	
Serie lunga - Lange Ausführung - Long models														
720W WL D20	20	20	150	98	17	9	3	APKT 1003...	VT25	BT08	0,320	●	258,00	
720W WL D25	25	25	150	94	19	9	3				0,500	●	284,00	
Serie extra lunga - Extralange Ausführung - Extralong models														
720W WXL D20	20	20	180	125	17	9	3	APKT 1003...	VT25	BT08	0,390	●	276,00	
720W WXL D25	25	25	200	140	19	9	3				0,680	●	293,50	
720W WXL D32	32	32	220	160	30	15	3	APKT 1604...	VT40	BT15	1,250	●	311,00	

● Disponibile - Lieferbar - On stock

○ A richiesta - Auf Anfrage - On request

2025

Ge Tooling

25

MILLING

MINIMILL

MOULDMILL

MICROTOOLS
AMS

MINITOOLS

GROOVING

GE DRILLS

NICECUT

YES DRILLS

SLIM CHUCK

INSERTS

SPEED TIGER

RICAMBI

PARAMETRI
INSERTI

SVASATORI-SBAVATORI 45°_ ENTGRATUNGSSENKER 45°_ DEBURRING COUNTERSINKS 45°

MILLING

MINIMILL

MOULDMILL

MICROTOOLS AMS

MINITOOLS

GROOVING

GE DRILLS

NICECUT

YES DRILLS

SLIM CHUCK

INSERTS

SPEED TIGER

RICAMBI

PARAMETRI INSERTI



NEW

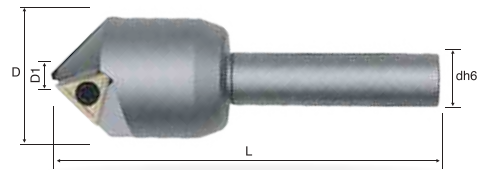

7545	D	D1	L	(mm)		Ødh6	y°	Z				KG		€
7545-VT13-C12-0422	22	4	85	12	45°	1	TCEX 13T302	SS1114	BT15	0,200	--	● 219,00		

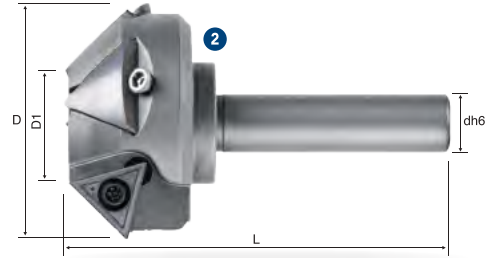
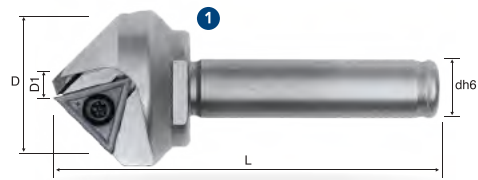

7745	Fig.	D	D1	L	(mm)		Ødh6	y°	Z				KG		€
7745VT16-C12-0525	1	25	5	78	12	45°	1	TCGX 163504	VT40	BT15	0,140	--	● 224,00		
7745VT16-C12-2545	2	45	25	78	12	45°	1				0,310	--	● 395,50		

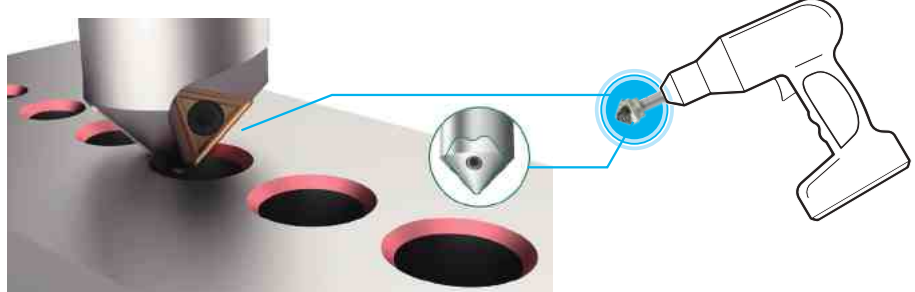

FRESE PER SMUSSI, SCANALATURE A V E CENTRARE 45°/30°
FAS-UND ZENTRIERFRÄSER 45°/30° _ CENTER DRILLING, CHAMFERING AND V GROOVING 45°/30°

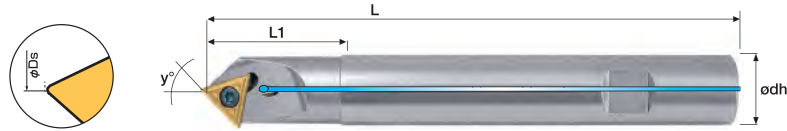

311 W	Ødh6	DS	↔ (mm)			Z	D _{min}	D _{max}	⚠	🌀	🔧	📊	🏭	STOCK	€		
			L	L1	Y°												
311.020 WW	20	0,4 / 0,8	115	40	45°	1	0,4	20	TCMX 16T3ZR 16T308ZR	VT40	BT15	0,240	💧 ●	216,00			
311.020 WWL	20	0,4 / 0,8	150	60	45°	1	0,4	20							0,320	💧 ●	243,00
311.020 WWXL	20	0,4 / 0,8	200	80	45°	1	0,4	20							0,430	💧 ●	277,50

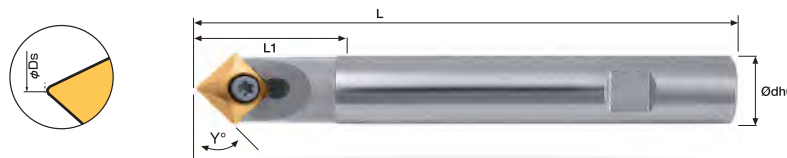

160 W	Ødh6	DS	↔ (mm)			Z	D _{min}	D _{max}	⚠	🌀	🔧	📊	🏭	STOCK	€
			L	L1	Y°										
160.45 W	16	0,8	120	40	45°	1	0.8	17	SEEX 12T408	VT4010	BT15	0,190	-- ●	155,00	
160.30 W	16	0,8	120	40	30°	1	0.8	21							0,200

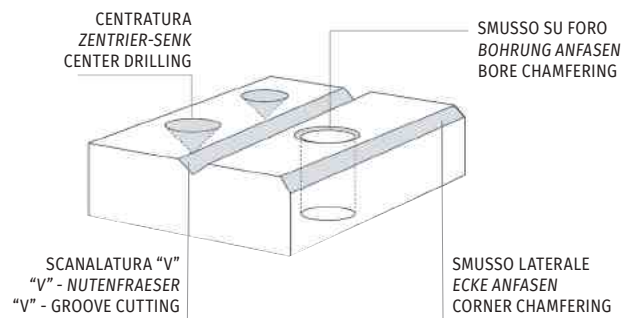

**FRESE PER SMUSSI E SVASATURE 30°, 45° E 60°
FRÄSER ZUM FASEN 30°, 45° E 60° _ CHAMFERING MILLING CUTTER 30°, 45° AND 60°**

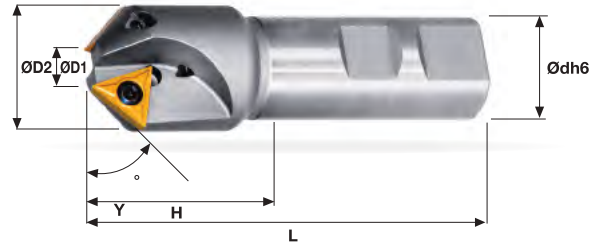
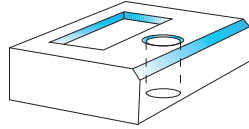

300 W	↔ (mm)							⚠	🌀	🔧	📊	🚰	STOCK	€
	ØD1	ØD2	L	H	Ødh6	Y°	Z							
300.016 WW	1,2	16	70	20	12	45°	1	TCMT 1102...	VT25B	BT08	0,060	💧	●	111,50
300.021 WW	6,2	21	90	35	20	45°	2	TCMT 16T3...	VT40	BT15	0,180	💧	●	151,50
300.032 WW	10,4	32,5	100	42	25	45°	2	TCMT 16T3...	VT40	BT15	0,380	💧	●	245,00
310.016 WW	5,4	16	70	20	12	60°	1	TCMT 1102...	VT25B	BT08	0,060	💧	●	111,50
310.027 WW	15,8	26	90	35	20	60°	2	TCMT 1102...	VT25B	BT08	0,180	💧	●	151,50
310.032 WW	20	35	100	39	25	60°	2	TCMT 16T3...	VT40	BT15	0,380	💧	●	245,00
315.032 WW	6	32	100	38	25	30°	2	TCMT 16T3...	VT40	BT15	0,380	💧	●	245,00

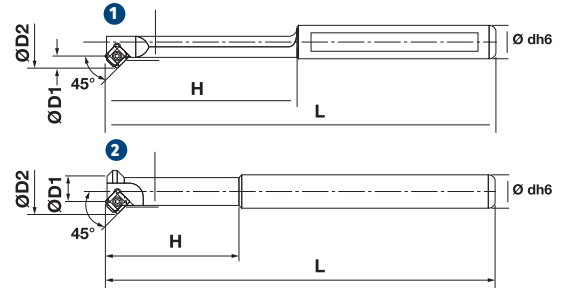
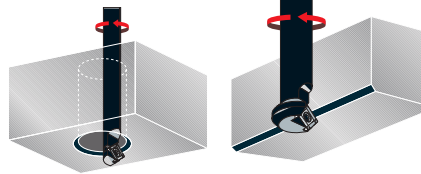

320 W	Fig.	↔ (mm)					⚠	🌀	🔧	📊	🚰	STOCK	€	
		ØD1	ØD2	L	H	Ødh6								
320.004 WW	1	4	12	80	28	12	1	SCMT 060204	VT25B	BT08	0,060	💧	●	146,50
320.011 WW	2	11	20	80	32	12	2	SCMT 09T308	VT40	BT15	0,070	💧	●	215,00
320.012 WW	1	12	23,7	100	37	20	1				0,190	💧	●	136,50
320.016 WW	2	16	28,8	100	32	16	2				0,150	💧	●	192,00
320.025 WW	2	30	42,3	100	32	20	3				0,270	💧	●	223,00
Serie lunga - Lange Ausführung - Long models														
320.012 WWL	1	12	23,7	200	37	20	1	SCMT 09T308	VT40	BT15	0,420	💧	●	165,50
320.016 WWL	2	16	28,8	200	32	16	2				0,300	💧	●	207,00
320.025 WWL	2	30	42,3	200	32	20	3				0,480	💧	●	263,00

321 W	Fig.	↔ (mm)					⚠	🌀	🔧	📊	🚰	STOCK	€	
		ØD1	ØD2	L	H	Ødh6								
321.004 WW	1	4	12	80	28	12	1	SPGT SPMT 060304	VT25	BT08	0,060	💧	○	140,50
321.011 WW	2	11	20	80	32	12	2	SPGT SPMT 09T308	VT35S	BT15	0,070	💧	○	206,50
321.012 WW	1	12	23,7	100	37	20	1				0,190	💧	○	131,00
321.016 WW	2	16	28,8	100	32	16	2				0,150	💧	○	184,50
321.025 WW	2	30	42,3	100	32	20	3				0,270	💧	○	214,00

IN ESAURIMENTO - SOLANGE DER VORRAT REICHT - WHILE SUPPLIES LAST

MILLING
MINIMILL
MOULDMILL
MICROTOOLS AMS
MINITOOLS
GROOVING
GE DRILLS
NICECUT
SLIM CHUCK
INSERTS
SPEED TIGER
RICAMBI
PARAMETRI INSERTI

FRESE PER SMUSSI E SVASATURE REGISTRABILE DA 10° A 80° _ FASENFRÄSER, WINKELVERSTELLBAR VON 10° BIS 80° _ MILLING CUTTERS FOR CHAMFERING-FLARING 10° TO 80°

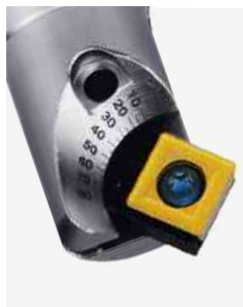





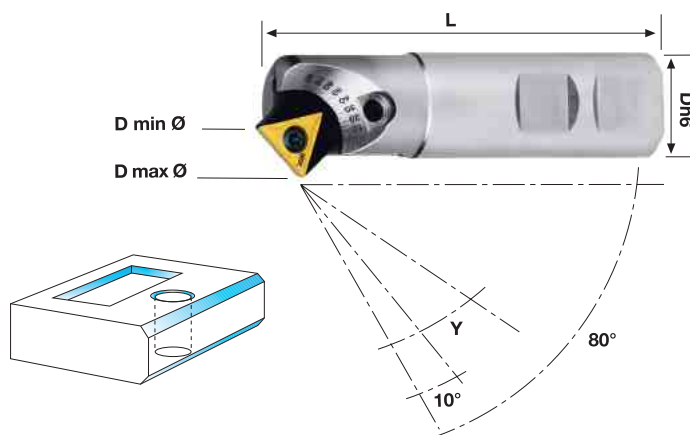







Con cassetta TCMT 16T3...
Mit Kasette TCMT 16T3...
With poket TCMT 16T3...

Con cassetta SCMT 1204...
Mit Kasette SCMT 1204...
With pocket SCMT 1204...



INCLUDE 2 CASSETTE T16 NEW + S12 NEW
INKLUSIVE 2 KASSETTEN T16 NEW + S12 NEW
INCLUDING 2 POCKETS T16 NEW + S12 NEW

340 W NEW	D h6	L	Y	Fig. 1		Fig. 2			KG	STOCK	€
				Dmin. Ø	Dmax. Ø	Dmin. Ø	Dmax. Ø	E			
340.020 W NEW	20	95	"	"	"	"	"	"	0,320	--	● 377,00
			10°	5	32	7,5	30	2,7			
			20°	6	33	10	32	3,6			
			30°	7	34	13	32,5	4,3			
			40°	10	33	16,5	33,5	4,5			
340.025 W NEW	25	95	45°	11	33	17,5	33,5	4,6	0,330	--	● 377,00
			50°	13	32	19	33,5	4,6			
			60°	16	31	22	33,5	4,3			
			70°	19	29	24,5	33,5	3,8			
			80°	23	27	27	31	3			
340.025 WL NEW	25	145	"	"	"	"	"	0,530	--	● 409,00	
340.025 WXL NEW	25	195	"	"	"	"	"	0,720	--	● 440,50	

	Cassetta Pocket	Inserto Insert	Vite inserto Insert screw	Vite cassetta Pocket screw	Chiave Key
 Fig. 1 Con cassetta TCMT 16T3... Mit Kasette TCMT 16T3... With pocket TCMT 16T3...	 T16NEW	 TCMT16T3...	 VT40	 M6-16	 BT15
 Fig. 2 Con cassetta SCMT 1204... Mit Kasette SCMT 1204... With pocket SCMT 1204...	 S12NEW	 SCMT1204...	 VT40S	 M6-16	 BT20

FRESE PER LAMATURA ED ALESATURA SENKFRÄSER UND AUSBOHRER _ SPOT FACING AND BORING MILLING CUTTERS

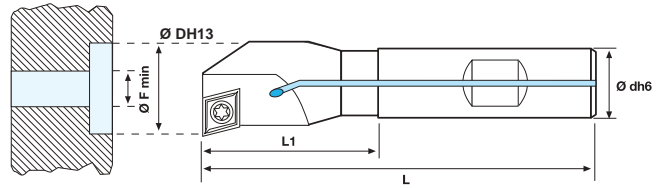
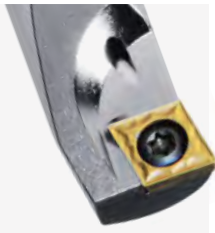

380 W	Ø D	L	L1 (mm)		Ø dh6	Ø Fmin	Z				KG	STOCK	€
380W W D10	10	85	15	12	4	1					0,060	●	100,00
380W W D11	11	85	15	12	4	1					0,060	●	100,00
380W W D12	12	85	18	12	4	1					0,070	●	100,00
380W W D13	13	85	23	12	5	1	CCMT 060204	VT25B	BT08		0,070	●	100,00
380W W D14	14	85	23	12	5	1					0,070	●	100,00
380W W D15	15	85	30	12	5	1					0,070	●	100,00
380W W D16	16	85	30	12	5	1					0,070	●	100,00
380W W D17	17	95	30	16	6	1					0,120	●	100,00
380W W D18	18	95	40	16	6	1					0,120	●	113,50
380W W D19	19	95	40	16	6	1					0,130	●	113,50
380W W D20	20	95	40	16	5	1					0,140	●	113,50
380W W D21	21	95	42	16	5	1					0,140	●	140,00
380W W D22	22	95	42	16	6	1					0,140	●	140,00
380W W D23	23	95	42	16	6	1					0,170	●	140,00
380W W D24	24	95	42	16	6	1					0,280	●	140,00
380W W D25	25	95	42	16	8	1	CCMT 09T304	VT40	BT15		0,300	●	140,00
380W W D26	26	120	56	20	8	1					0,300	●	140,00
380W W D27	27	120	56	20	9	1					0,310	●	140,00
380W W D28	28	120	56	20	10	1					0,320	●	140,00
380W W D29	29	120	56	20	11	1					0,320	●	145,50
380W W D30	30	120	56	20	12	1					0,340	●	145,50
380W W D31	31	120	56	20	12	1					0,360	●	145,50
380W W D32	32	120	56	20	13	1					0,360	●	145,50
380W W D33	33	120	56	20	14	1					0,360	●	145,50

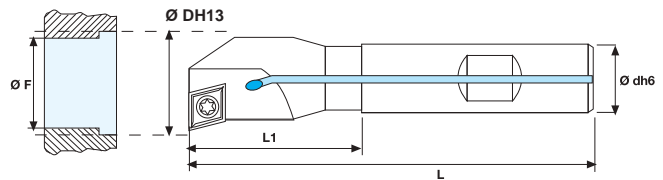

385 W	Ø D	L	L1 (mm)		Ø dh6	Ø Fmin	Z				KG	STOCK	€
385W W D10	9,8	90	23	8	4,5	1					0,060	●	106,50
385W W D11	10,8	105	24	10	3,5	1					0,060	●	106,50
385W W D12	11,8	105	25	10	3	1					0,070	●	106,50
385W W D13	12,8	105	26	10	2,5	1					0,070	●	106,50
385W W D14	13,8	110	27	12	3	1	CCMT 060204	VT25B	BT08		0,070	●	106,50
385W W D15	14,8	120	28	12	3,5	1					0,070	●	106,50
385W W D16	15,8	125	29	12	4	1					0,070	●	106,50
385W W D17	16,8	140	30	16	5	1					0,120	●	106,50
385W W D18	17,8	140	31	16	6	1					0,120	●	125,50
385W W D19	18,8	150	32	16	7	1					0,130	●	125,50
385W W D20	19,8	150	33	16	8	1					0,140	●	125,50
385W W D21	20,8	160	34	16	9	1					0,140	●	154,00
385W W D22	21,8	160	35	20	10	1					0,140	●	154,00
385W W D23	22,8	165	36	20	11	1					0,170	●	154,00
385W W D24	23,8	170	37	20	12	1					0,280	●	154,00
385W W D25	24,8	180	38	20	13	1					0,300	●	154,00
385W W D26	25,8	185	39	20	14	1	CCMT 09T304	VT40	BT15		0,300	●	154,00
385W W D27	26,8	190	40	20	15	1					0,310	●	154,00
385W W D28	27,8	190	41	20	16	1					0,320	●	154,00
385W W D29	28,8	200	42	20	17	1					0,320	●	161,50
385W W D30	29,8	200	43	25	18	1					0,340	●	161,50
385W W D31	30,8	200	44	25	19	1					0,360	●	161,50
385W W D32	31,8	200	45	25	20	1					0,360	●	161,50

FRESE PER LAMATURA 180° _ 180° SENKFRÄSER _ 180° SPOT-FACING END MILLS

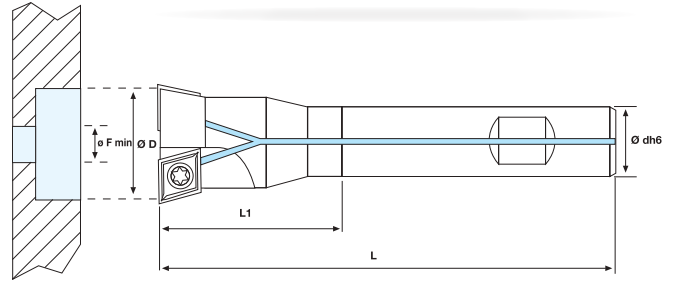

480 W	Ø D	L	L1	Ø dh6	Ø Fmin	Z								
			(mm)											
480W W D15	15	92	30	12	5	2	CCMT 060204	VT25B	BT08	0,070	●	●	184,00	
480W W D16	16	92	30	12	5	2				0,070	●	●	184,00	
480W W D17	17	94	32	16	6	2				0,120	●	●	184,00	
480W W D17,5	17.5	96	40	16	6.5	2				0,120	●	●	189,50	
480W W D18	18	97	41	16	7	2				0,120	●	●	189,50	
480W W D19	19	100	41	16	8	2				0,130	●	●	189,50	
480W W D20	20	102	41	16	9	2				0,140	●	●	215,00	
480W W D21	21	105	41	16	10	2				0,150	●	●	215,00	
480W W D22	22	110	41	16	11	2				0,160	●	●	227,00	
480W W D23	23	112	41	16	12	2				0,170	●	●	227,00	
480W W D24	24	115	41	16	13	2				0,180	●	●	227,00	
480W W D25	25	120	40	16	8	2				0,180	●	●	252,00	
480W W D26	26	125	55	20	9	2				0,270	●	●	252,00	
480W W D27	27	128	55	20	10	2				0,300	●	●	252,00	
480W W D28	28	130	55	20	11	2				0,310	●	●	252,00	
480W W D29	29	132	55	20	12	2	0,330	●	●	265,00				
480W W D30	30	134	55	20	13	2	0,340	●	●	265,00				
480W W D31	31	136	55	20	14	2	0,350	●	●	265,00				
480W W D32	32	138	55	20	15	2	0,370	●	●	265,00				
480W W D33	33	140	55	20	16	2	CCMT 09T304	VT40	BT15	0,390	●	●	265,00	
480W W D34	34	140	60	25	16	2				0,540	●	●	265,00	
480W W D35	35	140	60	25	17	2				0,550	●	●	265,00	
480W W D36	36	140	60	25	18	2				0,560	●	●	265,00	
480W W D37	37	140	60	25	19	2				0,580	●	●	265,00	
480W W D38	38	140	60	25	20	2				0,590	●	●	265,00	
480W W D39	39	140	60	25	21	2				0,610	●	●	290,00	
480W W D40	40	140	60	25	22	2				0,620	●	●	290,00	
480W W D41	41	140	60	25	23	2	0,640	●	●	290,00				
480W W D42	42	140	60	25	24	2	0,650	●	●	290,00				
480W W D43	43	150	70	25	24	2	0,670	●	●	341,00				
480W W D44	44	150	70	25	24	2	0,690	●	●	341,00				
480W W D45	45	150	70	25	24	2	CCMT 120404	VT50	BT20	0,700	●	●	341,00	
480W W D46	46	150	70	25	24	2				0,720	●	●	356,00	
480W W D47	47	150	70	25	24	2				0,740	●	●	356,00	
480W W D48	48	150	70	25	24	2				0,760	●	●	356,00	

● Disponibile - Lieferbar - On stock

○ A richiesta - Auf Anfrage - On request

2025

Ge Tooling

31

MILLING

MINIMILL

MOULDMILL

MICROTOOLS
AMS

MINITOOLS

GROOVING

GE DRILLS

NICECUT

YES DRILLS

SLIM CHUCK

INSERTS

SPEED TIGER

RICAMBI

PARAMETRI
INSERTI

FRESE PER LAMATURA A TIRARE 180° RÜCKWÄRTSSENKER 180° _ 180° BACK FACING MILLING CUTTERS

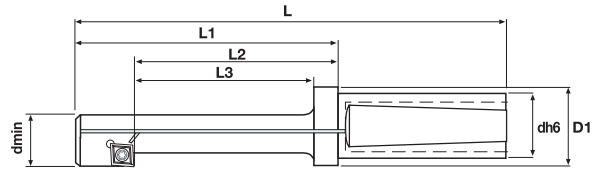

360 W

		D	Dmin	L	L1 L2 L3 (mm)			dh6	D1	e				KG		STOCK	€
360W D15	(HE)	15	8.5	105	55	42	35	20	25	3.5	CPMT 05T104 K300	VT22	BT07	0,170	--	●	254,50
360W D18	(HE)	18	10.5	112	62	47	40	20	25	4			0,170	--	●	254,50	
360W W D20	(HE)	20	13	117	67	52	45	20	25	3.75			0,180	💧	●	254,50	
360W W D24	(HE)	24	15	122	72	57	50	20	25	4.75	CCMT 060204	VT25B	BT08	0,190	💧	●	269,00
360W W D26	(HE)	26	17	132	82	67	60	20	25	5			0,210	💧	●	286,00	
360W W D30	(HE)	30	19	142	92	77	65	20	25	6			0,250	💧	●	313,00	
360W W D33	(HE)	33	21	152	102	82	75	20	25	6.5			0,270	💧	●	327,50	
360W W D36	(HE)	36	23	173	113	93	85	32	40	7			0,630	💧	●	337,00	
360W W D40	(HE)	40	25	183	123	103	95	32	40	8	CCMT 09T304	VT40	BT15	0,670	💧	●	368,00
360W W D43	(HE)	43	30	183	123	103	95	32	40	7			0,860	💧	●	385,00	
360W W D48	(HE)	48	33	223	163	143	135	32	40	8			1,120	💧	●	396,50	
360W W D53	(HB)	53	36	210	140	--	110	40	--	9			1,420	💧	●	407,00	
360W W D57	(HB)	57	39	220	150	--	120	40	--	9.5	CCMT 120404	VT50	BT20	1,620	💧	●	422,50
360W W D66	(HB)	66	45	245	165	--	135	50	--	11			2,620	💧	●	452,00	
360W W D76	(HB)	76	52	265	185	--	155	50	--	12.5			3,250	💧	●	499,50	

FRESE PER SMUSSO A TIRARE 45° _ RÜCKWÄRTSFAS 45° _ BACK CHAMFERING MILLING CUTTER 45°

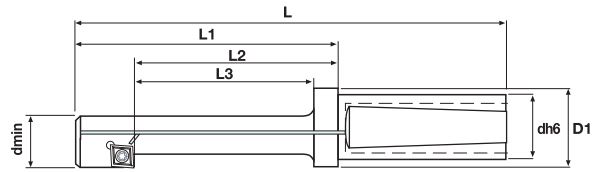

370 W

		D	Dmin	L	L1 L2 L3 (mm)			dh6	D1	e				KG		STOCK	€
370W D15	(HE)	15	10	105	55	42	35	20	25	2.70	TCMT 0802...	VT22B	BT06	0,170	--	●	280,50
370W W D20	(HE)	20	14	110	60	47	40	20	25	3.20			0,180	💧	●	280,50	
370W W D23	(HE)	23	17	120	70	57	50	20	25	3.20			0,190	💧	●	297,00	
370W W D27	(HE)	27	21	140	90	77	70	20	25	3.20	TCMT 1102...	VT25B	BT08	0,220	💧	●	315,00
370W W D31	(HE)	31	24	150	100	87	80	20	25	3.70			0,260	💧	●	345,00	

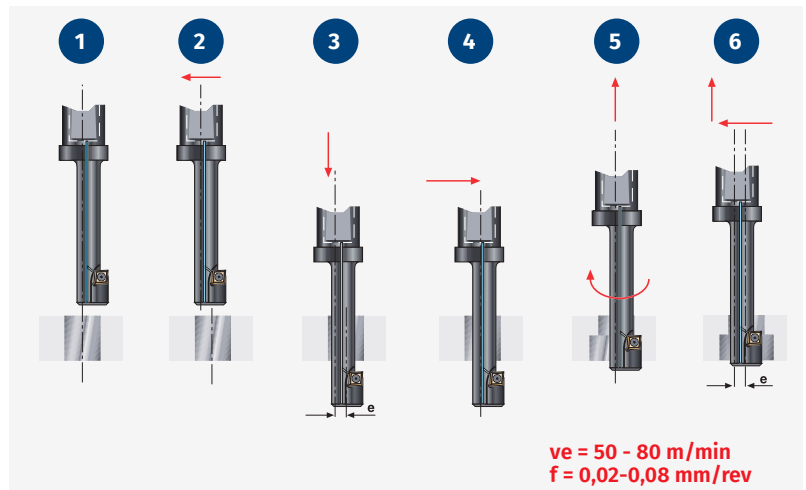
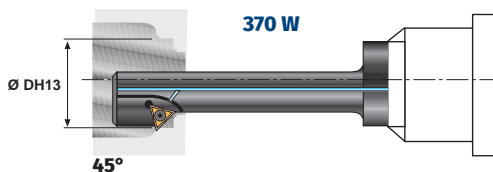
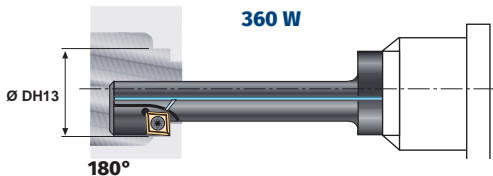

MILLING
MINIMILL
MOULDMILL
MICROTOOLS AMS
MINITOOLS
GROOVING
GE DRILLS
NICECUT
YES DRILLS
SLIM CHUCK
INSERTS
SPEED TIGER
RICAMBI
PARAMETRI INSERTI

BARENI REGISTRABILI PER ALESATURA EINSTELLBARE FEINBOHRSTANGEN _ ADJUSTEMENT BORING BARS



R.A.I.

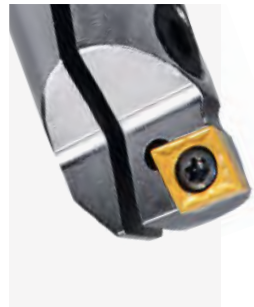

R.A.I. CCMT...

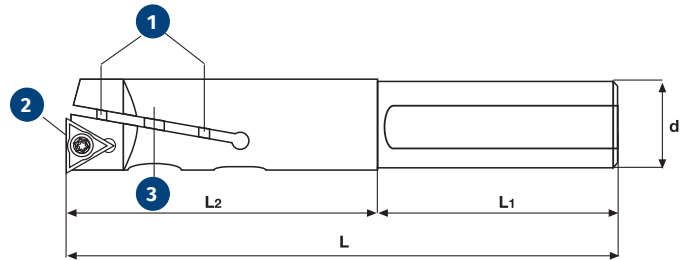

R.A.I.	↔ (mm)						1	2	3	INSERTO Wendeplatte insert	KG	STOCK	€		
	L	L1	L2	d	Dmin	Dmax									
R.A.I. 06	85	65	20	8	06	07	RE 11	VT24	BL 11		WCMT 0201...	0,020	--	○	255,00
R.A.I. 07	90	65	25	8	07	08	RE 9	VT20	BL 9		TPGX 0601 ..L	0,020	--	○	255,00
R.A.I. 08	90	65	25	8	08	10	RE 10	VT20	BL 10		TPGX 0601 ..L	0,030	--	○	255,00
R.A.I. 10	100	70	30	10	10	12	RE 0	VT20	BL 0		TPGX 0802 ..L	0,070	--	○	255,00
R.A.I. 12	105	65	40	12	12	15	RE 1	VT20	BL 1		TPGX 0802 ..L	0,100	--	○	276,00
R.A.I. 15	110	60	50	16	15	20	RE 2	VT20	BL 2		TPGX 0802 ..L	0,170	--	○	291,50
R.A.I. 20	120	60	60	20	20	25	RE 3	VT25	BL 3		TCMT 1102...	0,270	--	○	291,50
R.A.I. 25	140	70	70	25	25	30	RE 4	VT40	BL 4		TCMT 16T3...	0,480	--	○	317,50
R.A.I. 30	160	70	90	25	30	35	RE 5	VT40	BL 5		TCMT 16T3...	0,620	--	○	333,00
R.A.I. 35	170	70	100	32	35	40	RE 6	VT40	BL 6		TCMT 16T3...	1,050	--	○	374,50
R.A.I. 40	190	70	120	32	40	45	RE 7	VT40	BL 7		TCMT 16T3...	1,400	--	○	406,00
R.A.I. 45	220	70	150	32	45	50	RE 8	VT40	BL 8		TCMT 16T3...	2,040	--	○	478,50
R.A.I. 10 CCMT	100	70	30	10	10	12	RE 1	VT25B	BL 0		CCMT 0602...	0,070	--	○	255,00
R.A.I. 12 CCMT	105	65	40	12	12	15	RE 1	VT25B	BL 1		CCMT 0602...	0,100	--	○	276,00
R.A.I. 15 CCMT	110	60	50	16	15	20	RE 2	VT25B	BL 2		CCMT 0602...	0,170	--	○	291,50
R.A.I. 20 CCMT	120	60	60	20	20	25	RE 3	VT25B	BL 3		CCMT 0602...	0,270	--	○	291,50
R.A.I. 25 CCMT	140	70	70	25	25	30	RE 4	VT35	BL 4		CCMT 09T3...	0,480	--	○	317,50
R.A.I. 30 CCMT	160	70	90	25	30	35	RE 5	VT35	BL 5		CCMT 09T3...	0,620	--	○	333,00
R.A.I. 35 CCMT	170	70	100	32	35	40	RE 6	VT35	BL 6		CCMT09T3...	1,050	--	○	374,50
R.A.I. 40 CCMT	190	70	120	32	40	45	RE 7	VT35	BL 7		CCMT 09T3...	1,400	--	○	406,00
R.A.I. 45 CCMT	220	70	150	32	45	50	RE 8	VT35	BL 8		CCMT 09T3...	2,040	--	○	478,50
Serie lunga - Lange Ausföhrung - Long models															
R.A.I. 12 SL	130	70	60	12	12	15	RE 1	VT20	BL 1		TPGX 0802 ..L	0,200	--	○	354,00
R.A.I. 15 SL	140	70	70	16	15	20	RE 2	VT20	BL 2		TPGX 0802 ..L	0,270	--	○	385,00
R.A.I. 20 SL	150	70	80	20	20	25	RE 3	VT25	BL 3		TCMT 1102...	0,370	--	○	395,50
R.A.I. 25 SL	170	70	100	25	25	30	RE 4	VT40	BL 4		TCMT 16T3...	0,580	--	○	411,00
R.A.I. 30 SL	190	70	120	25	30	35	RE 5	VT40	BL 5		TCMT 16T3...	0,720	--	○	436,00
R.A.I. 35 SL	220	70	150	32	35	40	RE 6	VT40	BL 6		TCMT 16T3...	1,150	--	○	489,00

FRESE PER SMUSSI _ FASENFRÄSER _ CHAMFERING MILLING CUTTERS

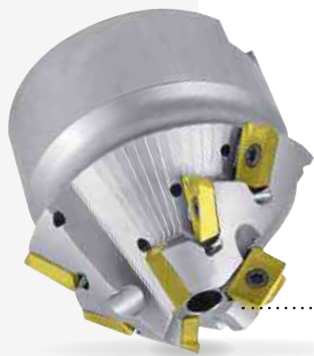

Ø d 16 = VT.FB.030
Ø d 22 = VT.FB.035

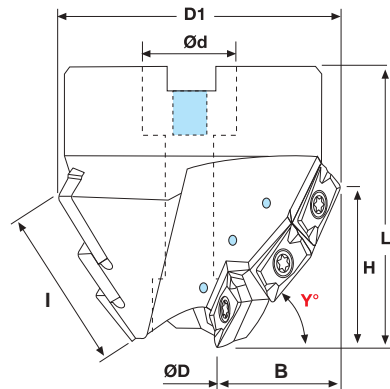

15°-20°-30°-40°-45°-60°-75°

FB: 030	ØD	D1	Ød	L	B	I	Y°	H	Z	K	APHT APHX APKT 1003...	VT25	BT08	KG	STOCK	€
FB.030.001 W	17	56	22	50	17,8	27,5	45°	19	9	3				0,470	●	692,00
FB.030.002 W	17	45	16	50	13	27,5	60°	24	9	3				0,280	●	692,00
FB.030.003 W	17	65	22	50	24	27,5	30°	13	9	3				0,600	●	692,00
FB.030.004 W	17	70	22	50	27	27,5	15°	7	9	3				0,770	●	692,00
FB.030.005 W	19	33	16	60	7	27,5	75°	27	9	3				0,270	●	692,00
FB.030.006 W	17	60	22	50	19	27,5	40°	17	9	3				0,520	●	692,00
FB.030.007 W	17	69	22	50	26	27,5	20°	9	9	3				0,700	●	692,00

Disponibile a richiesta anche FB 030 con gradazioni differenti Y°
Lieferbar auf Anfrage FB 030 mit verschiedenen Graden Y°
Available on request FB 030 with different grades Y°

K= Fattore d'avanzamento _ Vorschubfaktor _ Factor of feed



Ø d 22 = VT.FB.035
Ø d 27 = VT.FB.STANDARD
(DIN912 M12X 30)

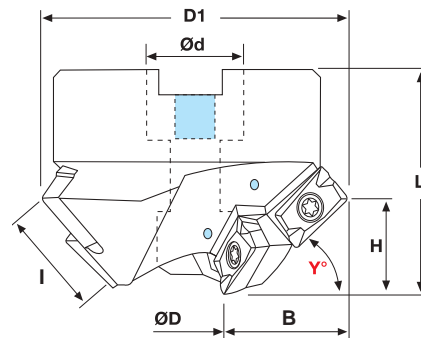

10°-15°-20°-30°-40°-45°-50°-60°-75°

FB: 035	ØD	D1	Ød	L	B	I	Y°	H	Z	K	APHT APHX APKT 1604...	VT40	BT15	KG	STOCK	€
FB.035.001 W	35	77,8	27	50	21,4	30	45°	21,5	6	3				0,780	●	692,00
FB.035.002 W	35	65	27	50	15,1	30	60°	26,5	6	3				0,580	●	692,00
FB.035.003 W	35	88	27	50	26,5	30	30°	15,0	6	3				1,000	●	692,00
FB.035.004 W	35	94	27	50	29,5	30	15°	8,0	6	3				1,190	●	692,00
FB.035.005 W	35	50,7	22	60	8	30	75°	29,5	6	3				0,460	●	692,00
FB.035.006 W	35	84	27	50	24,5	30	40°	19	6	3				0,860	●	692,00
FB.035.007 W	35	91	27	50	28,5	30	20°	10	6	3				1,130	●	692,00
FB.035.008 W	35	73	27	50	18	30	50°	23	6	3				0,820	●	692,00
FB.035.009 W	35	98	27	50	32	30	10°	6	6	3				1,260	●	692,00

Disponibile a richiesta anche FB 035 con gradazioni differenti Y°
Lieferbar auf Anfrage FB 035 mit verschiedenen Graden Y°
Available on request FB 035 with different grades Y°

K= Fattore d'avanzamento _ Vorschubfaktor _ Factor of feed

FRESE PER SMUSSI E FINITURE FASENFRÄSER ZUM SCHLICHTEN _ CHAMFERING MILLING CUTTERS FOR FINISHING



NEW

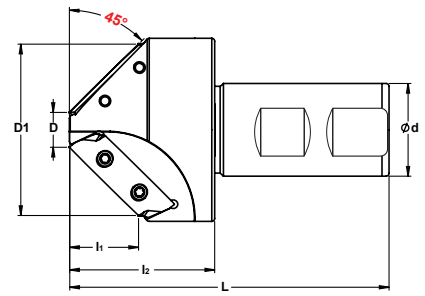

FSB W	D	D1	d	L	Y°	H	Z	K	XECX 32T3	VT40 FSB	BT15	KG	STOCK	€
FSB.012.001 W	12	59	32	110	45°	23,7	2	2				1,010	○	619,00

K= Fattore d'avanzamento _ Vorschubfaktor _ Factor of feed

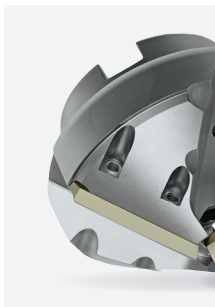

NEW

VT.FB.035

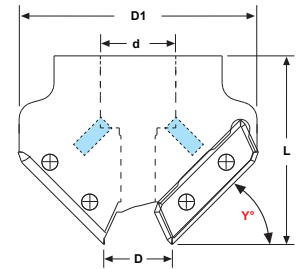

FSB M	D	D1	d	L	Y°	H	Z	K	XECX 32T3	VT40 FSB	BT15	KG	STOCK	€
FSB.020.001 MW	20	70	22	55	45°	22,8	3	3				0,730	●	692,00
FSB.020.002 MW	20	59,4	22	55	60°	28	3	3				0,520	●	692,00
FSB.020.003 MW	20	80	22	55	30°	17	3	3				1,030	●	692,00

K= Fattore d'avanzamento _ Vorschubfaktor _ Factor of feed



NEW

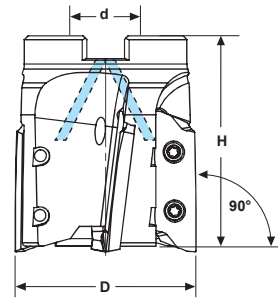

EFSM W	D	d	H	Z	XECX 32T3	VT40 FSB	BT15	KG	STOCK	€
EFSM W D50/4	50	22	60	4				0,550	○	692,00

CODICE ORDINE Bestell-Nr. Order No.	FIGURA Form Figure	(mm)					DENOMINAZIONE Bezeichnung Designation	NON RIVESTITI Unbeschichte Uncoated			RIVESTITI Beschichtet Coated				
		l	d	s	d1	r		k15	P25	P40	P200	P300	K300	K400	TIN PVD
NEW XECX		37	11,9	3,97	4,8	0,2	XECX 32T302							●	79,00
		37	11,9	3,97	4,8	2,0	XECX 32T320							○	79,00
		37	11,9	3,97	4,8	3,0	XECX 32T330							○	79,00
		37	11,9	3,97	4,8	4,0	XECX 32T340							○	79,00
		37	11,9	3,97	4,8	5,0	XECX 32T350							○	79,00

● Disponibile - Lieferbar - On stock

○ A richiesta - Auf Anfrage - On request

2025

Ge Tooling

35

MILLING

MINIMILL

MOULDMILL

MICROTOOLS
AMS

MINITOOLS

GROOVING

GE DRILLS

NICECUT

YES DRILLS

SLIM CHUCK

INSERTS

SPEED TIGER

RICAMBI

PARAMETRI
INSERTI

ESEMPIO SET _ SATZ BEISPIEL _ SET EXAMPLE

MILLING
MINIMILL
MOULDMILL
MICROTOOLS AMS
MINITOOLS
GROOVING
GE DRILLS
NICECUT
YES DRILLS
SLIM CHUCK
INSERTS
SPEED TIGER
RICAMBI
PARAMETRI INSERTI



BOX TCMT SET W

Frese smussi e svasature
Fasen Fräser
Milling cutters for chamfering

KG STOCK

Art. SET 300W W - 45°

- n° 1 300.016 WW
- n° 1 300.021 WW

0,270 ● SPECIAL NET PRICE PROMO



BOX TCMX SET W

Frese per smussi, scanalature a V e centrare 45°
Fas-und Zentrierfräser 45°
Center drilling, chamfering and V grooving 45°

KG STOCK

Art. SET 311W W

- n° 1 311.020 WW
- n° 4 TCMX 16T3ZR TiN

0,330 ● SPECIAL NET PRICE PROMO



BOX SEEX SET W

Frese per smussi, scanalature a V e centrare 45° / 30°
Fas-und Zentrierfräser 45° / 30°
Center drilling, chamfering and V grooving 45° / 30°

KG STOCK

Art. SET 160W - 45°

- n° 1 160.45 W
- n° 5 SEEX 12T408 TiN

0,250 -- ● SPECIAL NET PRICE PROMO



BOX TCEX SET C

Fresa per sbavatura e smusso 45°
Fasen Fräser 45°
Chamfering Milling Cutter 45°

KG STOCK

Art. SET 7545-0422

- n° 1 7545VT13-C12-0422
- n° 4 TCEX 13T302 K400

0,250 -- ● SPECIAL NET PRICE PROMO



BOX TCGX SET W

Fresa per sbavatura e smusso 45°
Fasen Fräser 45°
Chamfering Milling Cutter 45°

KG STOCK

Art. SET 7745-0525

- n° 1 7745VT16-C12-0525
- n° 4 TCGX 163504...

0,200 -- ● SPECIAL NET PRICE PROMO



GE TOOLING S.r.l.

Via Elsa Morante, 71 - 41123 Modena
Tel. +39 059 331543 - Fax. +39 059 822617
getools@getooling.it - www.getooling.it